

Scan Combiflex 330

Users Guide



SCANMASKIN
MACHINES-MINERALS-KNOW-HOW

Dear Customer!

Thank you for choosing Scanmaskin as your supplier.

We wish you all the best with your new Scan Combiflex™ 330 and hope that it lives up to your expectations.

Scanmaskin Sweden AB

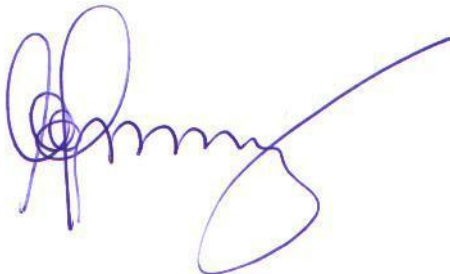

Claes-Göran Bergstrand
Managing Director

Address:

Scanmaskin Sweden AB

Box 187

SE-437 22 Lindome / Gothenburg

Sweden

Telephone: +46 (0) 31 99 49 70

Fax: +46 (0) 31 99 48 70

<http://www.scanmaskin.com/>

Important Information!

This User Guide only concerns the floor grinding machines “**Scan Combiflex 330**” hereby referred to as “**SC-330**”. SC-330 may only be used for grinding horizontal surfaces approved by Scanmaskin Sweden AB.

If SC-330 is used for other purposes or handled in ways other than that described in this User Guide, Scanmaskin Sweden AB disclaims all responsibility.

Especially note the section “**2 Safety Regulations**”. Read the User Guide before using the floor grinding machine SC-330. The spare parts, grinding discs used on SC-330 must be approved by Scanmaskin Sweden AB.

Table of Contents

| | | |
|-------|---|----|
| 1 | Specifications | 2 |
| 1.1 | Electrical specifications | 2 |
| 1.2 | Mechanical specifications | 3 |
| 1.3 | Tools..... | 3 |
| 1.4 | Range of application | 4 |
| 1.5 | Scope of supply | 4 |
| 1.6 | Overview | 5 |
| 2 | Safety Regulations | 6 |
| 2.1 | Legend..... | 6 |
| 2.2 | Safety precautions | 6 |
| 2.3 | Organizational measures | 7 |
| 2.4 | Personnel selection and qualification..... | 8 |
| 2.5 | Safety regarding operation of machine | 8 |
| 2.6 | Electrical safety..... | 9 |
| 2.6.1 | Cables..... | 10 |
| 2.6.2 | Using a generator | 10 |
| 2.7 | Definition of the “Safety off position” | 10 |
| 2.8 | Safety regarding maintenance | 11 |
| 2.9 | Safety regarding transport | 11 |
| 2.9.1 | Manual transport | 11 |
| 2.9.2 | Lifting | 12 |
| 2.9.3 | Inside vehicles..... | 12 |
| 3 | Transportation..... | 13 |
| 3.1 | Safety precautions | 13 |
| 3.2 | Manual transportation | 13 |
| 3.3 | Separation of machine..... | 13 |
| 3.4 | Inside vehicles | 13 |
| 4 | Operation | 14 |
| 4.1 | Precautions | 14 |
| 4.2 | Machine functions..... | 14 |
| 4.3 | Control device | 15 |
| 4.4 | Start up | 15 |
| 4.5 | Stop | 15 |
| 4.6 | Safety off position..... | 16 |
| 4.7 | Grinding | 16 |
| 4.8 | Changing tools | 16 |
| 5 | Maintenance..... | 17 |
| 5.1 | Precautions | 17 |
| 5.2 | Daily inspection prior to operation | 17 |
| 5.3 | Maintenance and inspection list | 17 |
| 5.4 | Grinding disc replacement / assembly | 18 |
| 5.5 | Cleaning the machine | 18 |
| 5.6 | Trouble shooting | 18 |
| 5.6.1 | Common faults..... | 18 |
| 6 | Spare parts..... | 19 |
| 7 | Warranty | 20 |
| 8 | EU Declaration | 21 |
| 9 | Grinding information | 22 |

| | | |
|-----|---|----|
| 9.1 | Grinding guide | 22 |
| 9.2 | Removal guide | 23 |
| 9.3 | Glossy concrete floors | 24 |
| 9.4 | Natural stone and terrazzo wet grinding | 25 |
| 10 | Alphabetical reference | 26 |
| 11 | Contact information | 27 |

1 Specifications

The SC-330 is available with different power inputs. This is described in the different sections later on in this chapter.

1.1 Electrical specifications

To find the specifications that apply to your machine, check the information plate on the machine.



Never connect the SC-330 to any other voltage or number of phases than described in this specification.



The power source must be fused according to “External fuse” in this specification; also the cables used must be marked and rated in accordance with the fuse used. Failure to comply with the correct fuses may cause fire or injuries.

| Power choice ¹ | 230 V 1~ ² | 110 V 1~ |
|----------------------------|----------------------------|------------------------------|
| Power | 2.2 kW (3 hp) | 1.5 kW (2 hp) |
| Current | 12 A | 18.5 A |
| Voltage | 200 – 240 V 1~ | 100 – 130 V 1~ |
| Frequency | 50 Hz +/- 5% | 60 Hz +/- 5% |
| External fuse ³ | 12 A | 20 A |
| Power inlet ⁴ | CEE 7/7 – 250V 16A + PE | NEMA 5-20 – 125V 20A + PE |

Table 1-1 Electrical specifications

All models are CE-marked.



If using a generator see “2.6.2 Using a generator”

¹ This refers to different power choices. Note that a SC-330 made for one choice of power must be used with the particular choice.

² Standard

³ Maximum current for the fuses used in the power source (*i.e. the distribution box*).

⁴ This is the standard inlet used. Machines sold outside of EU will be shipped either with a local standard inlet or an adapter.

1.2 Mechanical specifications

| | | |
|--------------------------------|---------------|---------|
| Model | SC-330 | |
| Grinding diameter | 325 mm | 13" |
| Grinding plate diameter | 325 mm | 13" |
| Grinding plate speed | 1420 rpm | |
| Mass | 70 kg | 154 lbs |

Table 1-2 Mechanical specifications

Dimensions of SC-330

| | | |
|---------------|---------|-------|
| Width | 440 mm | 17,5" |
| Height | 1000 mm | 39,3" |
| Depth | 810 mm | 37,4" |

Dimensions of shipping box

| | | |
|---------------|---------|-------|
| Width | 610 mm | 24.0" |
| Height | 1430 mm | 56.3" |
| Depth | 810 mm | 31.9" |

| | | |
|---|----------------|---------------|
| Ambient temperature during operation | -20°C to +40°C | -4°F to 104°F |
| Ambient temperature during storage | -20°C to +70°C | -4°F to 158°F |

1.3 Tools



The machine must be equipped with tools approved by Scanmaskin Sweden AB before operation.



See "9 Grinding " for information about available tools and "4.8 Changing tools" for information about how to change the tools.

The tools are fitted using the Snap-On system for easy fitting

Available tools

- SC-Tiger PCD
- Diamond tools
- Sand paper

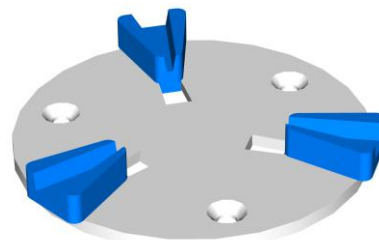

Figure 1-1 Snap-On plate with tools fitted.

1.4 Range of application



SC330 is exclusively designed to process horizontal surfaces. SC330 must not be used for other purposes than stated in this user guide. The manufacturer will not be liable for damage or injury resulting from incorrect usage of SC330. Failure to follow the directions in this user guide will void the warranty.

Typical applications

- Grinding next to a wall
- Removal of old coatings, carpets, putty from hard surfaces
- Removal of undulated concrete surfaces
- Preparation of the surface for coatings
- Polishing of the surface
- Removal of coating defects
- Removal of glue residues

SC-330 is recommended to smaller work sites.

1.5 Scope of supply

The following parts are included with the standard SC-330 grinding machine:

- User Guide
- 5 mm hexagon socket key

Machines sold outside of Europe will be either equipped with a local standard connector for the power inlet or the mating connector will be included and fitted at the main power inlet.



Read “2.6 Electrical safety” before connecting any included connectors.

1.6 Overview

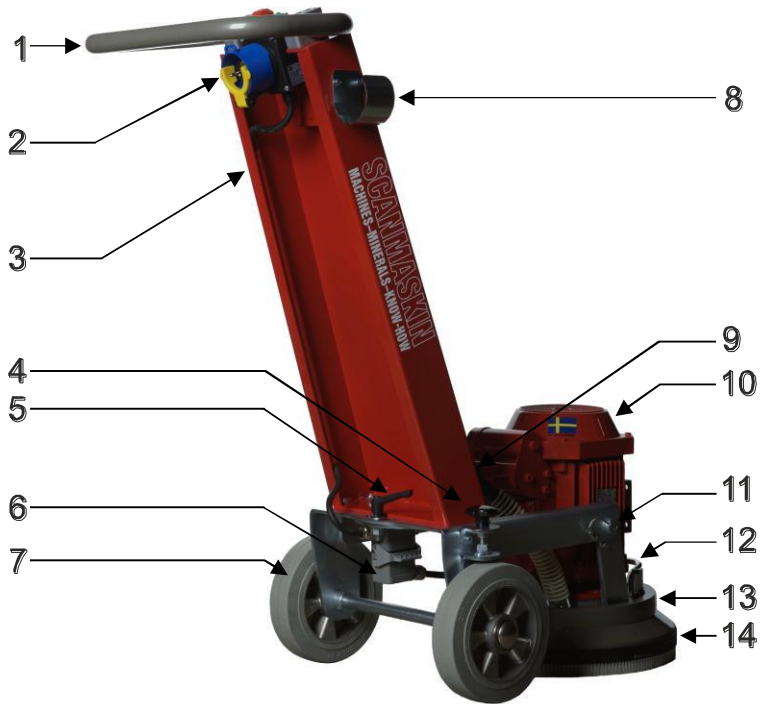

Figure 1-2 SC-330 overview

| Item | Description | Reference |
|------|----------------------------|--------------------|
| 1 | Handle | |
| 2 | Control device | 4.3 Control device |
| 3 | Frame | |
| 4 | Adjust wheel height | |
| 5 | Lock for adjust frame | |
| 6 | Connector motor - frame | |
| 7 | Wheel | |
| 8 | Dust collector hose holder | |
| 9 | Dust collector outlet | |
| 10 | Motor | |
| 11 | Pin | |
| 12 | Lifting handle | |
| 13 | Grinding head | 4.8 Changing tools |
| 14 | Dust cover | |





Table 1-3 Machine parts overview

2 Safety Regulations



Read this entire chapter carefully! Failure to comply with safety regulations may result in serious injuries or damages.

2.1 Legend

| | |
|--|--|
|  | Notation regarding safety |
|  | Notation regarding electrical safety |
|  | Notation regarding safety during transport |
|  | Tipping hazard |
|  | See reference |

2.2 Safety precautions



Any machine, if it is not used according the regulations, may be hazardous for operating, setting-up and service personnel. The operating authority is responsible for compliance with the safety regulations during operation and maintenance, and for the use of safety devices supplied with the machine, as well as the provision of appropriate additional safety devices!

Eye and ear protection must be worn at all times.

Never operate the machine when it's not in its upright position.

Make sure there is no debris in the work area.

Check the work area for screws or other hard objects in the concrete. Don't use the machine if there are any foreign objects stuck into the surface. Such objects must be removed prior to operation of machine.



Read “2.3 Organizational measures” and “2.5 Safety regarding operation of machine” thoroughly before operation!

2.3 Organizational measures



The user guide is to be kept near the location where the machine is being operated and must be within reach at all times.

In addition to this user guide general and legal regulations regarding accident prevention and environmental protection must be complied with as per local regulations.

Such duties may, for example, relate to the handling of hazardous substances, or to the provision and wearing of personal protection equipment, as well as compliance with traffic regulations.

The user guide must be supplemented by other instructions, including the duty to supervise and report incidents relating to particular working practices, for example work organization, work procedures and personnel safety.

Personnel entrusted with working with the machine must read the User Guide before starting work, in particular the “2 *Safety Regulations*” chapter. To read these instructions after work is commenced is too late. This particularly applies to incidental activities such as setting up the equipment, carrying out maintenance work or training staff to work with the machine.

From time to time the working practices of the operators are to be checked by a supervisor especially to the items regarding awareness of safety and hazards.

Operators must tie back long hair, and not wear loose clothing or jewelry including rings. There is a risk of injury through items getting caught, or being drawn into moving machinery.

Eye and ear protection must be worn at all times!

Use personnel protection equipment if necessary or required by local regulations! Take notice of all safety and hazard notices on the machine!

All safety and hazard notices at or on the machine must be kept complete and legible!

If safety-critical changes occur to the machine or its working method, the machine must be shut down immediately! The cause of the fault must be established, and rectified.

Changes, add-ons or conversation to the machine, which might impair safety, must not be made, without the manufacturer’s permission!

This applies in particular to the fitting and adjustment of safety devices.

Spare parts must comply with the technical requirements specified by the manufacturer. This is always guaranteed if original spare parts are used.

Intervals for recurring checks and inspections specified in this User Guide must be complied with!

To perform maintenance work correctly it is imperative to be equipped with the proper tools for the task in question.

Repairs may only be made by Scanmaskin Sweden AB certified service technicians.

Some grinding work may generate sparks under certain circumstances. Personnel working with the machine must therefore be aware of the risk of fire and how to handle a fire situation properly.

Do not use the machine in areas with highly flammable and/or explosive materials.

2.4 Personnel selection and qualification

Fundamental duties:

- Work with the machine may only be undertaken by trained personnel.
- Specify clearly the responsibilities of personnel for operation, setting up, servicing and maintenance work!
- Make sure that only authorized personnel operate or work with the machine!
- Define responsibilities of the machine operator, with regard to traffic safety regulations, and inform him not to take instructions from third parties who may not be complying with the local safety requirements.
- Personnel, who are being trained to operate equipment, may only use the machine under constant supervision of an experienced person!
- Work on electrical equipment may only be undertaken by a skilled electrician or by trained persons under the supervision of a skilled electrician, as well as in accordance with the local electrical engineering regulations.

2.5 Safety regarding operation of machine



Do not allow any method of working that impairs safety!

Recognized official procedures have to be used to ensure the machine is operated in safe and best conditions.

Only operate the machine when all safety devices and related safety equipment are present and operational!

Check the machine visually for any damage and defects at least once a day.

In the event of operational malfunctions the machine must be shut down immediately and secured!

Secure the work area around the machine in public areas providing a safety distance of at least 10 m (3.3 ft) from the machine.

Faults must be immediately rectified.

Carry out the switch on, and switch off operations in accordance with this user guide.

Before switching on the machine make sure that no-one can be endangered when the machine starts up.

Never operate the machine when not in its upright position.

Do not switch off or remove the exhaust and or the ventilation devices whilst the machine is running!

All persons in the proximity of the machine must wear ear and eye protection as well as safety shoes. In addition the machine operator must wear close-fitting protective clothing.

Only use extension cables that are sized and marked in accordance with the overall power consumption of the machine and the valid VDE guidelines.



See “2.6 Electrical safety” for further information.

Make sure there is no debris in the work area.

Check the work area for screws or other hard objects in the concrete. Don't use the machine if there are any foreign objects stuck into the surface. Such objects must be removed prior to operation of machine

2.6 **Electrical safety**



The power source must be equipped fuses according to the table in “1.1 Electrical specifications”. All cables used must be marked and rated according to the fuses used. Never connect the machine to a power source that does not provide protective earth!

Work on electrical equipment may only be undertaken by a skilled electrician or by trained persons under the supervision of a skilled electrician as well as in accordance with the local electrical engineering regulations.

Use only extension cables, that are used for extending the main cable, that are sized and marked in accordance with the overall power consumption of the machine and the valid VDE guidelines.

The electrical equipment for the plant must be inspected regularly. Defects such as loose connections or scorched cables must be rectified immediately. Call a skilled electrician or out customer services.

A second person must be in attendance whilst the electrical engineer is working on the equipment.

The work area must be secured against any third party entering the work area. Follow local electrical engineering regulations while working on the machine. Never leave a machine unattended. Use only tools that are insulated against electricity.

Only start work after you are familiar with the electrical engineering regulations that apply to the local area.

Only use voltage seekers that comply with the regulations when troubleshooting. From time to time check voltage seekers to ensure that they are operationally efficient.

2.6.1 Cables



Only use cables that are marked and rated according to the specifications in “1.1 Electrical specifications”. Don’t use excessive length of the cables. If a very long cable is needed we recommend that you use a cable rated for more current and connect it to a distribution central near the machine. Never lay the cable in a loop when operating the machine, this will cause the cable to heat up and may cause fire. See “Figure 2-1” for explanation.

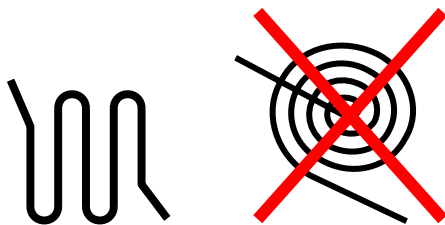

Figure 2-1 Recommended way to handle excessive cable length.

2.6.2 Using a generator



The generator must be equipped with protective earth and operated in accordance with the current EN-VDE directives (this applies to the protective earth conductor in particular) in order to ensure that all safety devices are functioning and eliminate possible damage to electrical components.

2.7 Definition of the “Safety off position”

The machine is in a safe condition where it cannot be any hazard.

How to set the machine in the Safety off position:

1. Switch off the machine
2. If a dust collector is used, switch it off
3. Wait for all drives to come to a complete stop
4. Disconnect the main power
5. Secure against unintended restart



Always disconnect the main power at the machine end to be able to prevent other persons from accidentally reconnect the main power while working on the machine.

2.8 Safety regarding maintenance

Set the machine into the Safety off position before beginning any work on the machine.



See “2.7 Definition of the “Safety off position””.

Never work on the machine while power is still connected!
All parts must have come to a complete stop before beginning any work!



When the machine is lying down on its back it might tilt to it's upwards position. Take extra care to prevent this from happening to ensure that no injuries or damages occur.



When the machine has been operated the segments, Snap-On plates and other parts on the gear barrel may be hot. Take extra care to prevent burn injuries.

Adjustment, servicing and inspection work on the period of time limits, specified in this User Guide as well as any information on the replacement or parts and equipment must be undertaken and/or complied with!

These activities may only be undertaken by qualified personnel.



The machine must not be connected to any power source while cleaning.



See “5.5 Cleaning the machine” for further information.

2.9 Safety regarding transport



Always remove the tools before transport. The tools may fall of or damage the surface the machine is transported along.

2.9.1 Manual transport



*When transporting the machine manually be observant about ramps and/or edges.
Follow local traffic regulations for the work site to prevent accidents. Failure to comply with these regulations may cause injuries or damages.*

2.9.2 Lifting



*The machine must be secured according to local safety regulations before lifted.
No person is allowed beneath a lifted machine! Observe the machines point of balance before lifting! Failure to comply with these regulations may cause injuries or damages. Only use straps approved for the weight and circumstances!*

2.9.3 Inside vehicles



Secure the machine according to local transport safety regulations before transporting the machine inside a vehicle.

3 Transportation

3.1 Safety precautions



Read “2.9 Safety regarding transport” before attempting to transport the machine.

3.2 Manual transportation

- Detach the tools according to the instructions in “4.8 Changing tools”.
- Tilt the machine backwards.
- Push the machine in desired direction.

3.3 Separation of machine

If the machine needs to be transported in a limited space it can be separated into two parts. On each side of the grinding head / motor assembly there is two pins, each fastened by a locking clip. To separate the machine, disconnect the motor cable; remove the locking clips and the pins. Take extra care to prevent the frame from falling backwards.

3.4 Inside vehicles

- Detach the tools according to the instruction in “4.8 Changing tools”.
- Secure the machine inside the vehicle.



Secure the machine according to local transport safety regulations before transporting the machine inside a vehicle. Failure to secure the machine may result in injuries or damages.

4 Operation

4.1 Precautions



Any machine, if it is not used according to the regulations, may be hazardous for operating, setting-up and service personnel. The operating authority is responsible for compliance with the safety regulations during operation and maintenance, and for the use of safety devices supplied with the machine, as well as the provision of appropriate additional safety devices!

Never operate the machine without proper tools.

Eye and ear protection must be worn at all times.

Never operate the machine when it's not in its upright position.

Make sure there is no debris in the work area.

Check the work area for screws or other hard objects in the concrete. Don't use the machine if there are any foreign objects stuck into the surface. Before operating the machine such objects must be removed.



Read “2 Safety Regulations” before operating the machine.

4.2 Machine functions

The machine has one grinding head that rotates in counter clockwise direction if you lock from above. The grinding head is equipped with a snap-on plate. See “**Fel! Hittar inte referenskölla.**”.



The machine's motor is equipped with a thermal protection circuit that will shut down the machine in the event of high motor temperature. Wait at least 15 minutes before operating the machine again if this occurs.

4.3 Control device

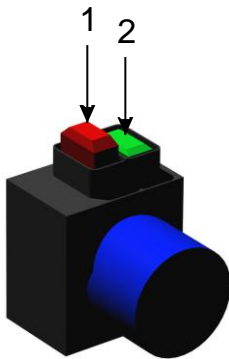

Figure 4-1 SC-330 control device

| Item | Function | Description |
|------|----------|-------------------|
| 1 | Stop | Stops the SC-330 |
| 2 | Start | Starts the SC-330 |

Table 4-1 Description of control device

4.4 Start up



See "4.1 Precautions" before starting the machine.

How to start the machine

- Make sure that the machine is equipped with the right "snap on" tools.
- Make sure that the main power and hoses for the dust collector are connected to the machine.
- Turn on the dust collector if used.
- Push the handle downwards to lift the grinding head from the ground.
- Press the start button (2) on the control device.
- Lower the grinding head down to the floor.
- Never let go of the handle during operation.

4.5 Stop

How to stop the machine

- Press the stop button (1)
- Wait until the machine comes to a complete stop before letting go of the handle
- If a dust collector is used, turn off

4.6 Safety off position

When working on the machine, either maintenance or tool change, the machine must be set to the “Safety off position”. See “2.7 Definition of the “Safety off position”” for further information.

4.7 Grinding

Refer to “9 Grinding” for instructions and information about grinding.

4.8 Changing tools



Before changing tools, read “2.8 Safety regarding maintenance”.

This illustration shows how to change the Snap-On tools.

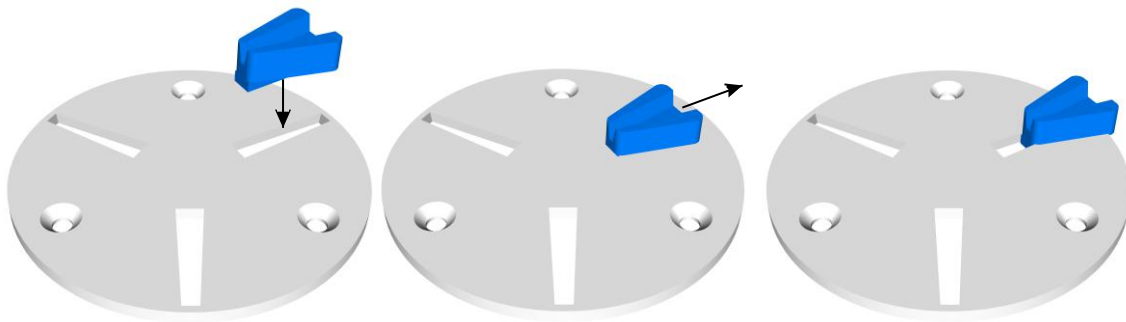

Figure 4-2 How to fit the diamond segments on the Snap-On plate

- Insert the segment at the widest part of the slot
- Push the segment outwards
- The segment is now fit on the Snap-On plate

To make sure that the segment is secured, use a small plastic hammer and slightly hit the segment outwards. In reverse this technique can be used to loosen segments that are stuck.

5 Maintenance

5.1 Precautions

Set the machine into the Safety off position before beginning any work on the machine.



See “2.7 Definition of the “Safety off position””.



Read “2.6 Electrical safety” before beginning any maintenance work.

Never work on the machine while power is still connected!

All parts must have come to a complete stop before beginning any work!



When the machine is lying down on its back it might tilt to it's upwards position. Take extra care to prevent this from happening to ensure that no injuries or damages occur.



When the machine has been operated the segments, Snap-On plates and other parts on the gear barrel may be hot. Take extra care to prevent burn injuries.

Adjustment, maintenance and inspection work must be undertaken by qualified personnel.



The machine must not be connected to any power source while cleaning.

5.2 Daily inspection prior to operation

Inspect the following items prior to operation

- Inspect the wheels for damage.
- Inspect the grinding discs and hubs.
- Inspect the grinding head, dirt between the Snap-On plate and the grinding hub may lower the flexibility of the grinding head.
- If any screws appear loose, tighten them.
- Look over the machine for any other damage.

5.3 Maintenance and inspection list

| | |
|------------------------|---|
| Daily | <ul style="list-style-type: none">▪ Inspect the wheels▪ Inspect the grinding heads▪ Look for any other damage |
| 12 hours after service | <ul style="list-style-type: none">▪ Tighten all screws |

5.4 Grinding disc replacement / assembly

Follow these steps to replace the Snap-On plate

- Make sure the machine is in its “Safety off position”
- Tilt the machine backwards and secure it.
- Remove any tools used according to ”4.8 Changing tools”.
- Remove the three nuts that are tightened under the three screws holding the Snap-On plate.
- Loosen the three screws holding the Snap-On plate.
- Replace the Snap-On plate.
- It’s recommended that new screws are used to fasten the replacement Snap-On plate.
- It’s also recommended that copper paste is used on the surface of the screw hole at the Snap-On plate.
- Tighten all screws by hand and make sure that they are secured.
- Use new nuts to secure the screws underneath the snap-On plate.

5.5 Cleaning the machine



Before starting to clean the machine, make sure it is in its ”Safety off position”



The power must not be connected while cleaning the machine.

Do not use highly pressurized water to clean the machine.
Water and soap is recommended.

5.6 Trouble shooting

5.6.1 Common faults

| Symptom | Cause | Correction | A ⁵ |
|---|--|--|----------------|
| The machine won't start | <ul style="list-style-type: none"> ▪ There is a power failure from the power supply | <ul style="list-style-type: none"> ▪ Inspect the fuses in the worksites fuse box ▪ Inspect cables ▪ Measure that the main voltage is present and at full voltage at the cable end near the machine. | O E E |
| The machine only operates while the start button is depressed | <ul style="list-style-type: none"> ▪ The motor is overheated | <ul style="list-style-type: none"> ▪ Wait until the motor is cool again | O |
| | <ul style="list-style-type: none"> ▪ The control device is damaged | <ul style="list-style-type: none"> ▪ Replace the control device | S |
| The machine is weak and might stop when on the ground. | <ul style="list-style-type: none"> ▪ There is a voltage drop at the power supply | <ul style="list-style-type: none"> ▪ Inspect the fuses in the worksites fuse box ▪ Inspect cables ▪ Measure that the main voltage is present and at full voltage at the cable end near the machine. | O E E |
| | | <ul style="list-style-type: none"> ▪ Make sure that the cable is not too long. If the cable should be too long, use a cable with higher rating to a distribution box nearer the machine. | O |
| The machine vibrates a lot | <ul style="list-style-type: none"> ▪ The grinding speed is to high | <ul style="list-style-type: none"> ▪ Lower the speed, only on machines with variable speed. | O |
| | <ul style="list-style-type: none"> ▪ The tools are damaged | <ul style="list-style-type: none"> ▪ Inspect the tools ▪ Change the tools if needed | O O |

6 Spare parts

For information about spare parts, contact Scanmaskin Sweden AB

7 Warranty

This product from Scanmaskin Sweden AB comes with a twelve month warranty. If the product does not function satisfactorily during this period, Scanmaskin will return the product to full working order for normal use which the product is intended for – with no charge for labor or spare parts, according to the following conditions:

1. The warranty only applies to persons that have legal right to the equipment during the warranty period.
2. The manufacturer's undertaking is limited to the repair of defective parts or the replacement of these according to the manufacturer's assessment. Costs and risks for transport as well as dismantling and reinstallation of the product / products and other direct or indirect costs, associated with the repair in question, are not covered by this warranty.
3. Periodic inspections, adjustments, maintenance work and changes are not covered by the warranty.
4. Scanmaskin is not liable for any damages to grinding discs or other similar equipment.
5. The warranty only applies to material and design deficiencies and does not apply in the following cases:
 - a. Damage caused through accidents, carelessness, changes, use of spare parts or grinding tools that are not original components, or incorrect use and installation.
 - b. Damage caused by lightning, water, fire, vandalism, incorrect mains voltage, incorrect ventilation or other causes that lie outside of the manufacturer's control.
6. Scanmaskin reserves the right to modify the design – or make improvements without obligation to change previously manufactured products.
7. All warranty repairs must be carried out by Scanmaskin or by a Scanmaskin authorized repair workshop. Costs for repairs, carried out by an unauthorized workshop, will not be reimbursed by Scanmaskin. If such repairs damage this product these are not cover by the warranty agreement.

8 EU Declaration

Declaration of CE conformity

| | |
|----------------|---|
| Manufacturer | Scanmaskin Sweden AB |
| Address | Heljesvägen 10 427 36 Lindome / Gothenburg Sweden |
| Product | Grinding machine |
| Product name | Scan Combiflex 330 |
| Serial number | _____ |

The product conforms with the following EU guidelines

| | |
|----------------------|---|
| Machine directives | 2006/42/EG |
| EMC | 2004/108/EG |
| LVD | 2006/95/EG |
| Harmonized standards | EN ISO 13850 EN ISO 12100-1/-2 EN ISO 60204-1 |

Location of issue Lindome / Gothenburg / Sweden

Authorized representative Claes-Göran Bergstrand
Managing Director



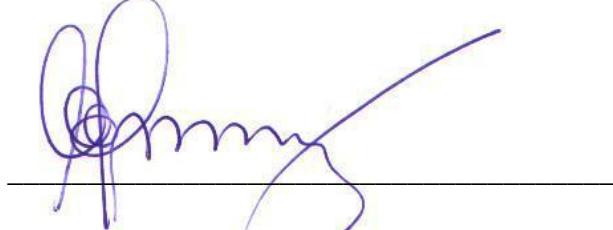

Scanmaskin Sweden AB
2011-01-01



Claes-Göran Bergstrand
Managing Director



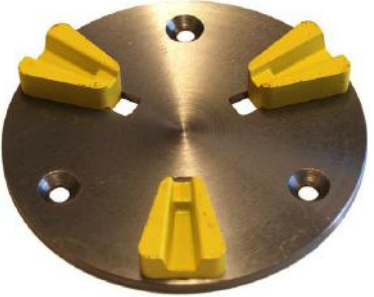

9 Grinding information

9.1 Grinding guide

| | | |
|---|--|--|
|  <p>SC-Silver</p> <p>This is a very aggressive grinding tool with very rough diamonds.</p> |  <p>SC-Black</p> <p>This is our standard grinding tool for rough grinding. This tool produces a roughly structured surface. The SC-Black is suitable for removal of glue, paint, and putty residues.</p> |  <p>SC-Blue</p> <p>This is our standard grinding tool for fine grinding. This tool produces a finished, structure-free surface for painting or lacquering. The SC-Blue is also a good choice for removing the gloss from old surfaces or paint removal.</p> |
|  <p>SC-Green</p> <p>This grinding tool is for very fine grinding. This tool produces a finished, structure-free surface for painting or lacquering.</p> |  <p>SC-White</p> <p>This grinding tool has got very fine diamonds and produces a very smooth surface.</p> |  <p>SC-Yellow</p> <p>This is our finest metal bounded diamond grinding tool.</p> |

| Designation | Description | Application example |
|-------------|----------------|--|
| SCSSS | Extremely soft | Concrete floors with a glossy and hard surface |
| SCSS | Extra soft | Extra hard concrete |
| SCS | Soft | Hard concrete |
| SCM | Medium hard | Normal concrete for aggressive grinding |
| SCL | Hard | Normal concrete with longer service life |
| SCX | Extra hard | Soft concrete and putty |
| SCXX | Very hard | Rain-damaged concrete, rough concrete surfaces |
| SCXXX | Extremely hard | Cast concrete |

9.2 Removal guide

| | | |
|---|---|---|
|  <p>SC-Tiger Silver 592013</p> <p>This is a very aggressive tool that can remove many kind of coatings. This tool has a very high removing capacity and can even remove thick layers of paint, lacquer, epoxy, acrylics, glue and putty residues.</p> |  <p>SC-Tiger Gold 521018</p> <p>This is a very aggressive tool that can remove most kind of coatings. The Tiger Gold has an extremely high removing capacity and can even remove thick layers of paint, lacquer, epoxy, acrylics, glue and putty residues. The SC-Tiger Gold has a longer service live than the Silver.</p> |  <p>SC-Scratch + Claw 592044</p> <p>This tool resembles the SC-Scratch but its aggressiveness is increased by six PCD claws on each segment.</p> |
| |  <p>SC-Scratch</p> <p>SC-Scratch is a tool that helps you to quickly remove the gloss from very hard concrete surfaces. Due to the diamonds being sintered on the surface of the segment, you attain immediate results even when removing paint, etc. The SC-Scratch is available in several sizes of diamonds.</p> | |

9.3 Glossy concrete floors

Seven steps to a glossy concrete floor.

| | | |
|--|--|--|
|  <p>Step 1. SC-Blue Grinding with this tool reveals the stone that will be visible in the glossy Combifloor.</p> |  <p>Step 2. SC-Green</p> | <p>Impregnate with SC-Proof. Wait about 10 to 12 hours.</p> |
|  <p>Step 3. SC-White</p> |  <p>Step 4. RDC-Blue 593034</p> |  <p>Step 5. RDC-Red 593035</p> |
|  <p>Step 6. RDC-White 593036</p> |  <p>Step 7. RDC-Green 593038</p> | <p>It is very important to carefully vacuum the floor between each grinding step.</p> |

9.4 Natural stone and terrazzo wet grinding

Seven steps to a glossy floor.

| | | |
|--|--|---|
|  <p>Step 1. RSM Metal bounded for wet grinding</p> |  <p>Step 2. RDR-Black 593033</p> |  <p>Step 3. RDR-Blue 592065</p> |
|  <p>Step 4. RDR-Red 592066</p> |  <p>Step 5. RDR-White 592067</p> |  <p>Step 6. RDR-Yellow 592068</p> |
| |  <p>Step 7. RDR-Green 592069</p> | |

10 Alphabetical reference

| | | | |
|---------------------------------------|----|-----------------------------|----|
| C | | O | |
| Contact information | 27 | Overview | |
| Control device | 15 | SC-330..... | 5 |
| D | | S | |
| Dimensions | | Separation of machine | 13 |
| SC-450..... | 3 | Snap-On-plate | |
| E | | replacing..... | 18 |
| EU Declaration..... | 21 | Specifications | |
| F | | Electrical | 2 |
| Fuse | | Start..... | 15 |
| External..... | 2 | Stop | 15 |
| G | | T | |
| Grinding guide | 22 | Tools | |
| I | | Available tools | 3 |
| Inspection | | changing | 16 |
| daily | 17 | Transport..... | 13 |
| Maintenance and inspection list | 17 | manual..... | 13 |
| | | Trouble shooting | |
| | | common faults..... | 18 |
| | | V,W | |
| | | Warranty | 20 |

11 Contact information

Sweden

Main office

Box 187
SE-437 22 Lindome

Phone: +46 (0) 31 99 49 70
Fax: +46 (0) 31 99 48 70
E-mail: scanbolagen@scanmaskin.com
Internet: <http://www.scanmaskin.com/>

Denmark

Torvegade 22
DK-7330 Brande

Phone: +45 97 18 00 58
Fax: +45 97 18 45 58
E-mail: scanbolagen@scanmineral.com
Internet: <http://www.scanmaskin.com/>

Norway

Postboks 6, Furuset, N-1001 Oslo
Prof. Birkelandsvei 24 c
N-1081 Oslo

Phone: +47 22 30 67 50
Fax: +47 22 30 29 10
E-mail: scanmineral@scanmineral.no
Internet: <http://www.scanmaskin.com/>

Finland

Urakoitsijantie 15 D 2
FIN-06450 Porvoo / Borgå

Phone: +358 19 57 55 001
Fax: +358 19 57 55 002
E-mail: info@scanmineral.fi
Internet: <http://www.scanmaskin.com/>